

## Cofefe Maker Instructions

- Applicable Models: C09(G)/C09(H)/C09(J)/C09(N)
- Applicable coffee: Aluminum encapsulated coffee capsule
- Voltage: 220V~ 50 Hz
- Power: 500W
- Capacity: 40ml
- Main cord: 0.75 M
- Size: 150mmX 150mmX 358 mm (LxWxH)

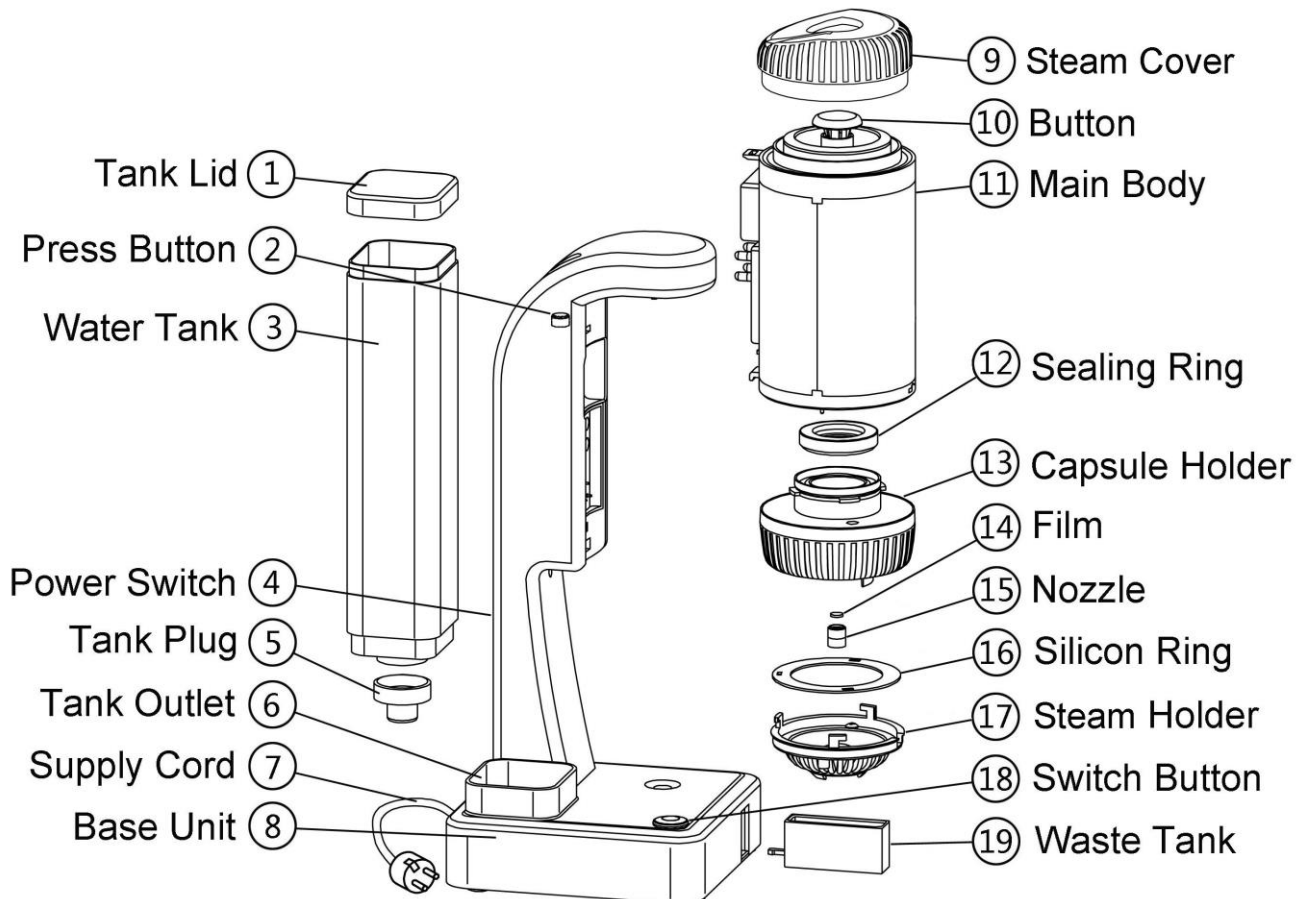

### Cautions:

- After having the packaging removed, make sure that the appliance is intact. If in doubt do not use the appliance and contact your sales agent.
- The packaging materials and plastic bags etc. must not be left within the reach of children.
- This appliance is manufactured to make espresso coffee with specialized capsule and water only. Do NOT use capsules made of or containing plastic.
- This appliance is designed for and can only be used for household purposes. All other use is considered improper and as a result dangerous and voids the warranty.
- The manufacturer declines all liability for any damage deriving from improper, incorrect and unreasonable use of the appliance.
- In the event of faults or malfunctioning of the appliance, cut off the power as soon as possible, do not tamper with it, and contact service centres that are authorised by the manufacturer at once. For any repairs, only use components that are provided by the manufacturer.

- The appliance is not intended for use by children as well as persons with reduced physical, sensory or mental capabilities, or lack of experience or knowledge, unless they have been given supervision or instructions.
- Please keep away from children while using to avoid burns, due to the small amount of hot steam out from the coffee machine.
- When cleaning, never immerse the support base in water, to avoid leakage or short circuit, because there are electronic components inside.
- The capsule holder can only be opened when the indicator light of the switch button is blue; do not open it when it is red.
- Do not touch the press button by mistake. Grasp the main body tightly before pressing the press button if it's necessary to take it out.
- During operation, the appliance is hot with steam emitting, it is normal but please avoid touching lest burns should occur.
- After continuous use of the appliance for more than 5 times, the appliance will accumulate a certain amount of heat and reach a certain temperature, it must be stopped for half an hour before using again.
- Switch off when the appliance is not in use to avoid unintended activation.
- If the supply cord is damaged, it must be handled by the manufacturer, its service agent or qualified persons in order to avoid a hazard.

### Important

Before use

Please prepare purified water, specialized coffee capsule and cleaned capsule holder before starting to brew coffee.

If the appliance has started working, please do not stop halfway, and do not open the capsule holder until the blue light is on.

Keep the capsule holder clean all the time.

### Operation---Espresso coffee

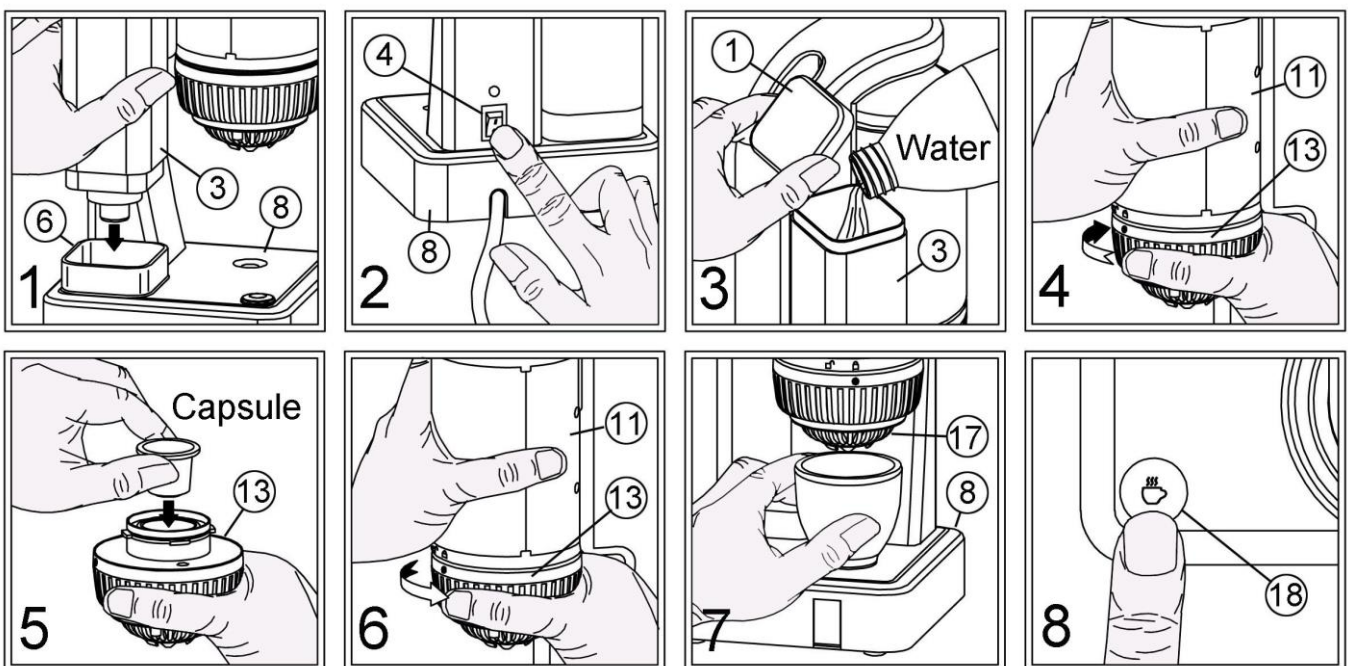

1. Fig 1 The water tank must be inserted into the tank outlet, and the appliance assembled properly.

2. Fig 2 Press the power switch to "I", and the indicator light turns blue.

3. Fig 3 Remove the tank lid then pour room-temperature purified water into the water tank, at a maximum of 550ml, and don't over spill. **The appliance cannot work when the tank is short of water.**
4. Fig 4 Unscrew the capsule holder from the main body, from the sign ● to the unlocking sign ◻, and take out the capsule holder.
5. Fig 5 Put the **specialized capsule** into the capsule holder. Don't rip the foil of the capsule. **Do NOT use capsules made of or containing plastic.** Coffee cannot be brewed with unspecialized capsule, and it's not safe as well.
6. Fig 6 Screw the capsule holder into the main body, from the sign ● to the locking sign ◻. **If the sign ● out of place, the appliance will not work.**
7. Fig 7 Put a cup under the capsule holder, and insert the waste tank into the base unit.
8. Fig 8 Press the switch button about **1 second**, and the indicator light changes from blue to red, the coffee machine begins heating. After about 90 seconds, the red indicator light starts flashing with a beeping sound, the coffee is finished and begins dripping with a small amount of steam letting out. Then the red flashing indicator light changes to blue, the appliance stops automatically and you can take out a nice cup of espresso and the appliance is ready for a second cup of coffee. If you want to go on with another cup of coffee, please start with step 4.

**Attention:** When the appliance is working, it will let out some steam with popping sound, which is normal.

**Attention:** The appliance is hot when working, which is normal, but don't touch it.

**Attention:** Do not open the capsule holder when the appliance is working. If you need to stop the appliance during operation or it stops accidentally, you can turn off the power switch. But you need to wait half an hour before disassembling the appliance. To restart or resume the operation, you have to pour out the water in the main body first. See the Fig. The appliance can make 5 cups of coffee continuously at most, and must stop working for half an hour before further operation.

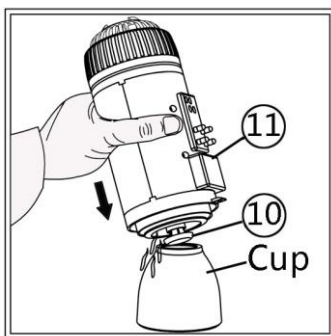

**Attention:** When water shortage occurs in the water tank during operation, the red indicator light will flash 3 times with 3 beeps, then please pour purified water into the water tank, and then the appliance will continue to work, but the finished coffee may not be perfect. The appliance will stop working finally when water shortage still exists in the water tank.

### Cleaning & Maintenance

- When cleaning the outside, use only a cloth. Be careful not to wet any electronic parts. Do not clean appliance by dishwasher.
- It is recommended to clean the capsule holder, gas holder and waste tank, and extrude the waste water from the sponge after each use.
- It is recommended to clean the internal system of the appliance automatically by operating without the capsule during the first use and after using every 8 to 10 times;
- After the water tank is emptied and refilled, the appliance should be operated without the capsule once. Coffee should not be brewed until the internal system is cleaned automatically. If brewing coffee immediately after cleaning, pay attention to the hot water and steam from the gas holder to avoid burns.
- When the machine is taken out, the water in the water tank and the residual liquid in the waste water tank

must be cleaned up to avoid the residual liquid from polluting the inside and outside of the machine.

## Cleaning the appliance

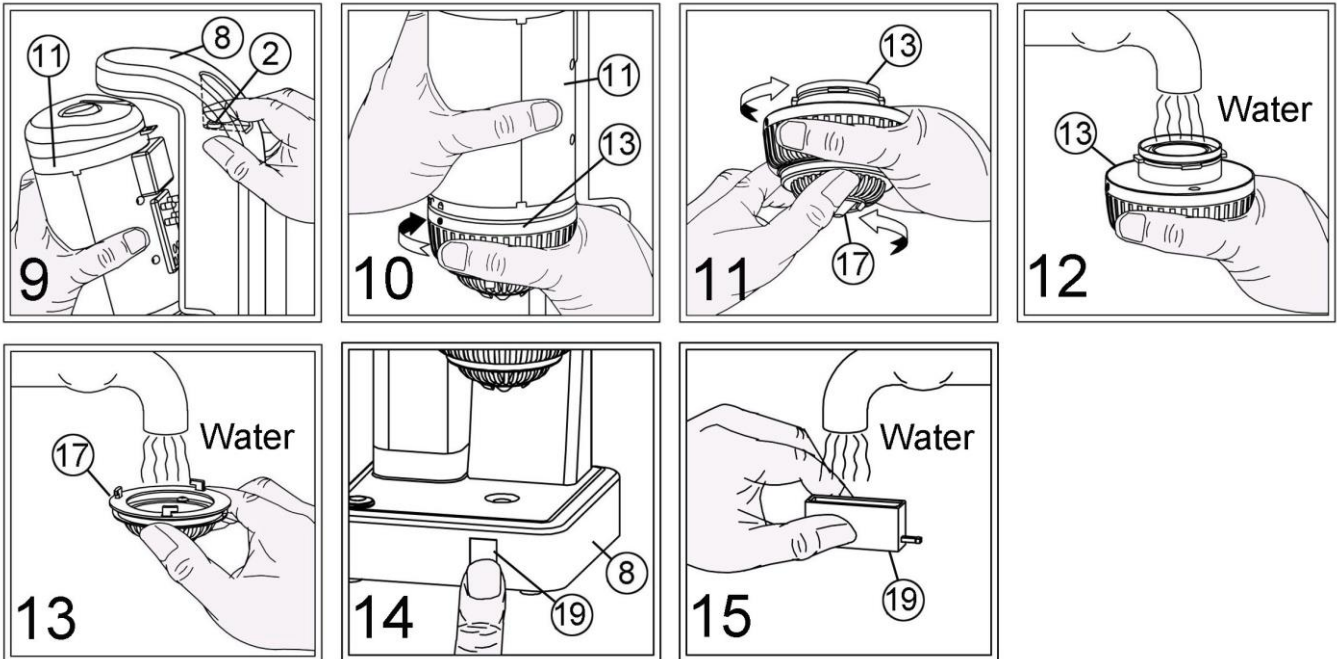

9. Fig 9 Grasp the main body tightly, press the press button, and take out the main body by leaning outward. **Before pressing the press button, make sure the main body is gasped tightly, otherwise the main body will fall down.**

10. Fig10 Open the capsule holder from the sign ● to the unlocking sign ◻, and take out from the main body.

11. Fig 11 Take out the gas holder from the capsule holder.

12. Fig 12 Clean the capsule holder with clean water.

13. Fig 13 Clean the gas holder with clean water.

14. Fig 14 When the waste tank is full, push it in then let go to take it out.

15. Fig 15 Rinse it with clean water or warm water, and remove the water, then reverse the above operation.

**Attention:** In course of reassembling the main body, buckle the bottom part first and then push the upper part in, otherwise poor contact will occur.

## Replace the film of the nozzle

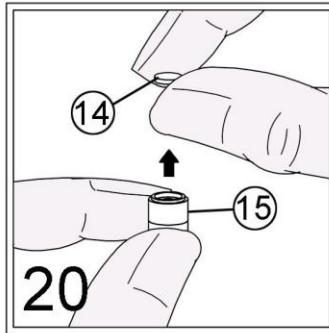
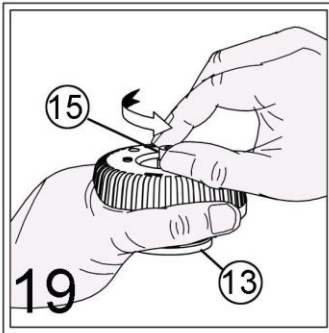
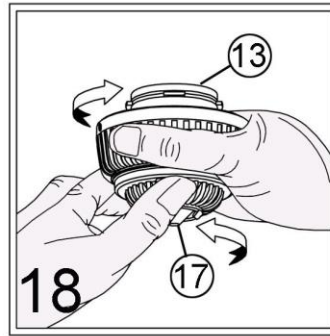
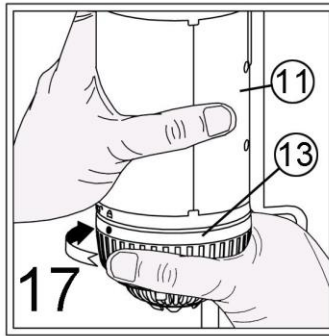

16. Fig 16 Grasp the main body tightly, press the press button, and take out the main body by leaning outward. **Before pressing the press button, make sure the main body is gasped tightly, otherwise the main body will fall down.**

17. Fig 17 Open the capsule holder from the main body, from the sign ● to the unlocking sign ◻, and take out the capsule holder.

18. Fig18 Take out the gas holder from the capsule holder.

19. Fig 19 Take out the nozzle from the capsule holder.

20. Fig 20 Take out the old film, replace with a new one, and do the reverse above operations.

**Attention:** In course of reassembling the main body, buckle the bottom part first and then push the upper part in, otherwise poor contact will occur.

### Replace sealing ring

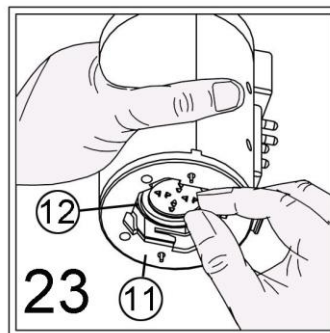
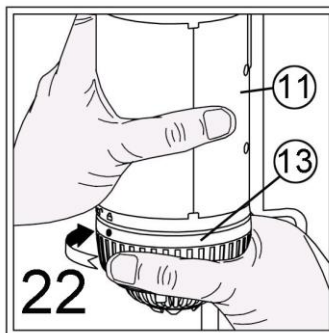

21. Fig 21 Grasp the main body tightly, press the press button, and take out the main body by leaning outward. **Before pressing the press button, make sure the main body is gasped tightly, otherwise the main body will fall down.**

22. Fig 22 Open the capsule holder from the main body, from the sign ● to the unlocking sign ◻, and take out the capsule holder.

23. Fig 23 Take out the old sealing ring from the bottom of main body, replace the new sealing ring, and do the reverse above operations.

**Attention:** In course of reassembling the main body, buckle the bottom part first and then push the upper part in, otherwise poor contact will occur.

## Problem analysis

1. Press the switch button, but there is no light and it fails to work.

Corresponding action: Is it connected to the main socket in the wall? Is the power switch press to "I" ? Are both the upper and lower buckles of the main body buckled into the base unit? Does the machine stand by too long? To restart the machine, you need to turn off the power switch again and pause for more than 5 seconds before pressing the power switch to "I".

2. When finished, only water and no coffee.

Corresponding action: Is the capsule specialized? Does the sealing ring come loose? Is the sealing ring and the capsule holder clean or not? Is the edge of the capsule or of the inner side of the sealing ring damaged? If the sealing ring is damaged, replace with a new one, detailed in Fig. 23.

3. The coffee comes out without coffee oil!

Corresponding action: Is the coffee capsule specialized for the appliance? Is the nozzle loose? Is there a lack of water in the water tank? Is the edge of outer side of the sealing ring damaged? If the sealing ring is damaged, replace with a new one, as in Fig. 23. If not the above, the film of the nozzle should be replaced, detailed in Fig. 20.

4. Press the switch button, the indicator light is flashing but it fails to work.

Corresponding action: Is the capsule holder inserted into the main body properly? Is the main body buckled into the base unit? Does water shortage occur in the water tank?

5. No coffee coming out.

Corresponding action: Is the button which should be in the upper part of the main body still in place? Is there a lack of water in the water tank?

6. A leakage from the bottom of the water tank.

Corresponding action: Is the water tank inserted into the tank outlet? Is the tank plug screwed tightly? Is there a sealing ring in the tank plug?

7. An outflow of waste water.

Corresponding action: Is the waste water in the waste tank full?

8. If the problem cannot be resolved by the above, it must be repaired or replaced by the manufacturer, its service agent or qualified persons in order to avoid risks.